



INSTALL TIME: 15 Mins

- (A) Decide on a suitable position for your Cargo Rail to be mounted. Take some time to consider the best suited method of securing the Rail and what fasteners and tools will be required to complete the job. It is advised that M6 Button Head Bolts are used and that the Rail is secured in a minimum of two places.

- (B) Should you wish to fit the End Caps to the Rail, you will need to drill a 8.5 mm Hole - 15 mm in from each end as shown.

Only fit the End Caps once the Rail has been fitted to the vehicle and the Channel Nut has been inserted (Refer to Step C). The Caps are fitted by pushing the Caps into the Rail and clipping them into position as shown.

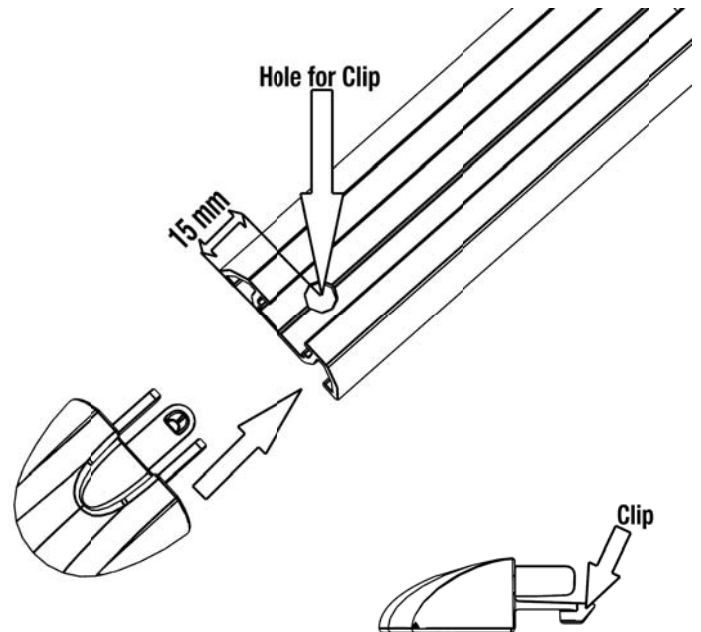

- (C) Once the Rail has been secured in position, slide the Channel Nut into the Rail. Fasten the Eye Bolt and Flat Washer to the Channel Nut as shown.

