



FRONT RUNNER
VEHICLE OUTFITTERS

PRO UNDER RACK TABLE BRACKET

ENG

TBRA016

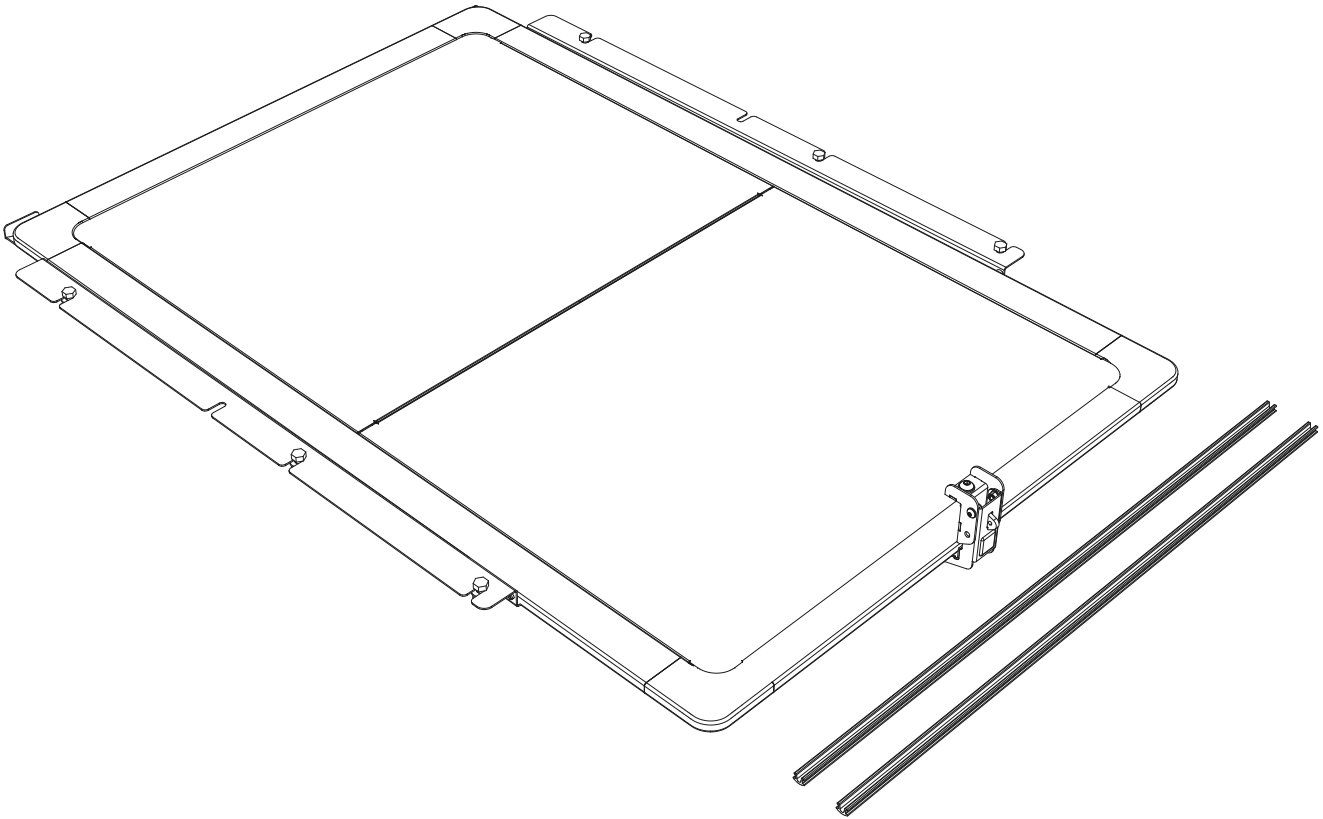

READ ME !

Thank you for purchasing a Front Runner Pro Under Rack Table Bracket.
Before you start, take a moment to familiarize yourself with this Fitting Instruction and the components received.
Refer to Page 2 for a list of all the components, quantities and tools required.

IMPORTANT WARNING!

IT IS CRITICAL THAT ALL FRONT RUNNER PRODUCTS BE PROPERLY AND SECURELY ASSEMBLED AND ATTACHED TO YOUR VEHICLE.
IMPROPER ATTACHMENT COULD RESULT IN AN AUTOMOBILE ACCIDENT, AND COULD CAUSE SERIOUS BODILY INJURY OR DEATH.
YOU ARE RESPONSIBLE FOR ASSEMBLING AND SECURING ALL FRONT RUNNER PRODUCTS TO YOUR VEHICLE. CHECKING THE ATTACHMENTS PRIOR TO USE, AND PERIODICALLY INSPECTING THE PRODUCTS FOR ADJUSTMENT, WEAR AND DAMAGE. THEREFORE YOU MUST READ AND UNDERSTAND ALL OF THE INSTRUCTIONS AND PRECAUTIONS SUPPLIED WITH YOUR FRONT RUNNER PRODUCT PRIOR TO INSTALLATION OR USE.
IF YOU DO NOT UNDERSTAND ALL OF THE INSTRUCTIONS AND CAUTIONS, OR IF YOU HAVE NO MECHANICAL EXPERIENCE AND ARE NOT THOROUGHLY FAMILIAR WITH THE INSTALLATION PROCEDURES,
YOU SHOULD HAVE THE PRODUCT INSTALLED BY A PROFESSIONAL INSTALLER OR OTHER QUALIFIED PERSONNEL.

1

GET ORGANIZED

Here is what you are looking at for TBRA016

IN THE BOX

1	2 X	Table Slide - 1 Left + 1 Right
2	2 X	T-Slot Rubber
3	8 X	M8x16 Hex Bolt
4	8 X	M8x19 Flat Washer
5	8 X	M8 Nyloc Nut
6	8 X	M8 Nut Cap
7	2 X	M6 Nyloc Nut
8	2 X	Uni Screw Cap
9	2 X	M6x12x1ss Flat Washer
10	2 X	M6x12 Button Head Bolt
11	1 X	M8x20 Button Head Bolt
12	1 X	M8 Flat Washer
13	1 X	Latch

TOOLS NEEDED

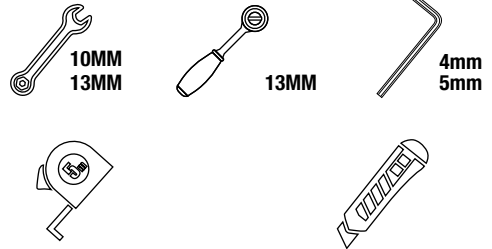
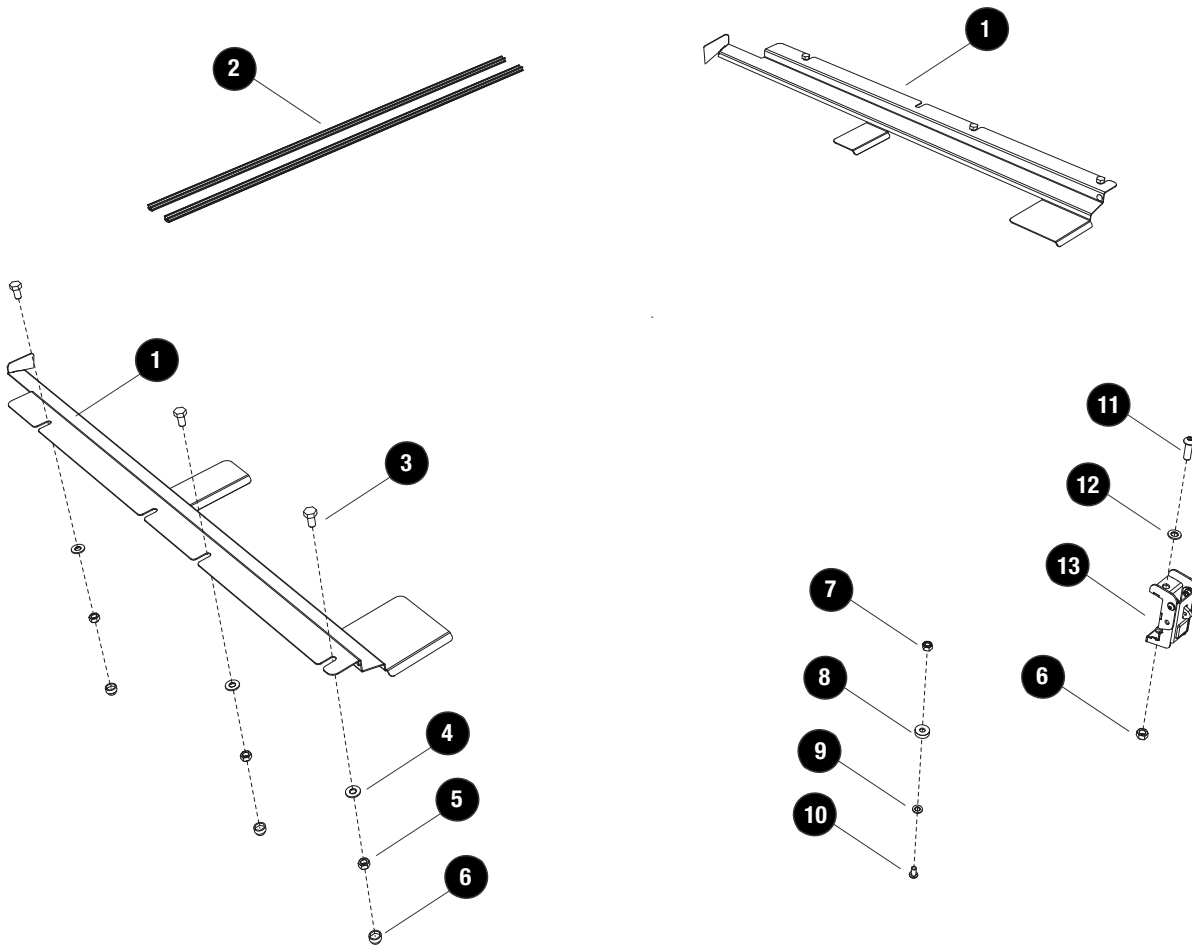

FIGURE 1.1



If you wish to mount your table at the rear of your rack, please refer to Section 2.

If your rack is mounted using a foot rail system and you wish to side mount your table, please refer to Section 3.

2

MOUNTING THE TABLE AT THE REAR OF THE RACK

2.1

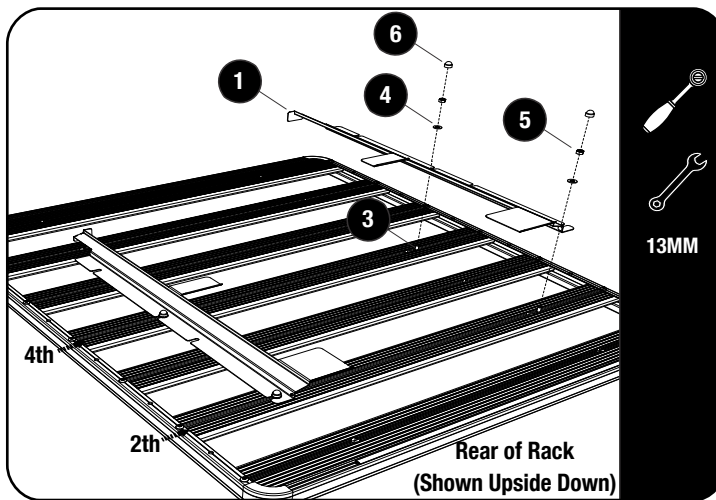

Working underneath and from the rear of the rack, slide two M8x16 Hex Bolts (Item 3) into the second and fourth slats of the rack through the machined slots. Loosely secure the table slides (Item 1) to the rack using items 4 and 5 as shown.

2.2

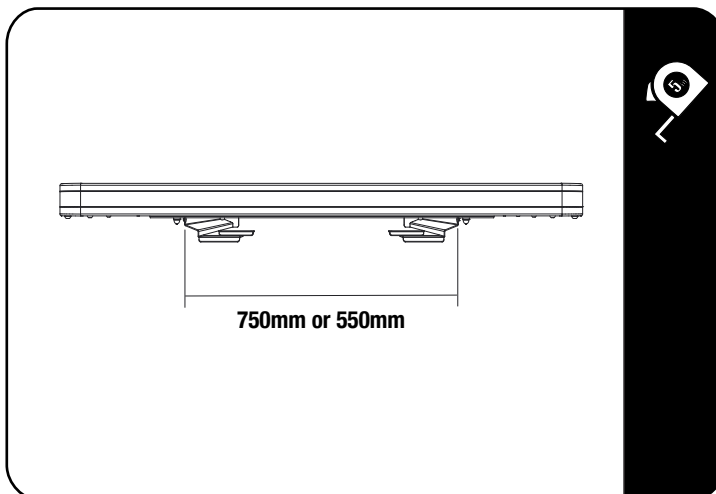

Depending on the width of your table, space the two table slides either 750mm or 550mm apart. Tighten all the Nyloc nuts and place a M8 nut cap (Item 6) over each Nyloc nut. See diagram 2.1

2.3

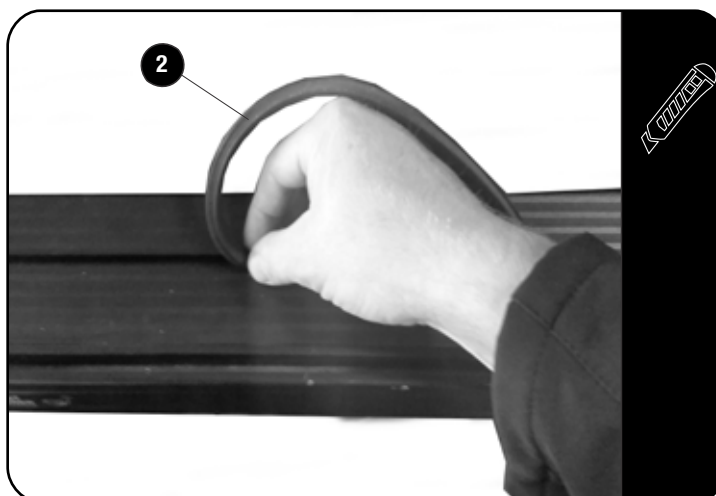

Cut the T-slot Rubber (Item 2) to suite the width of your rack and insert into the rear T-slot of the first slat by pinching/squeezing the sides of the rubber together and pushing/rolling the rubber into the T-slot as shown.

2

MOUNTING THE TABLE AT THE REAR OF THE RACK

2.4

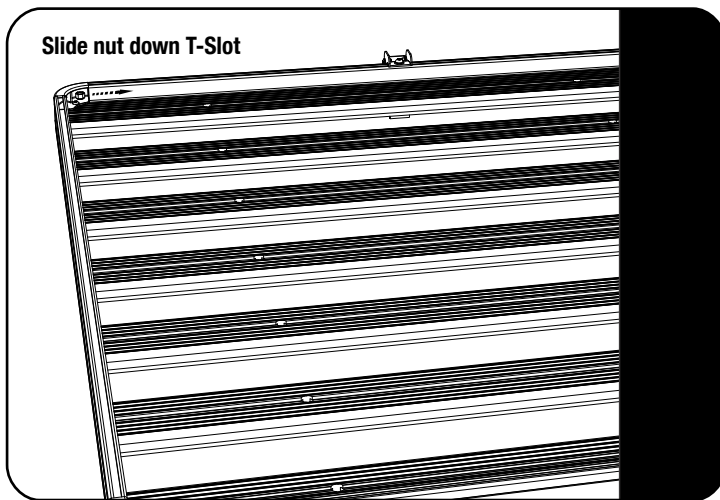

↻ Insert a M8 Nyloc Nut (Item 6) dome side down into the "U" channel of the rack through the gap in the corner as shown. Slide the Nyloc Nut to the center of the rack.

2.5

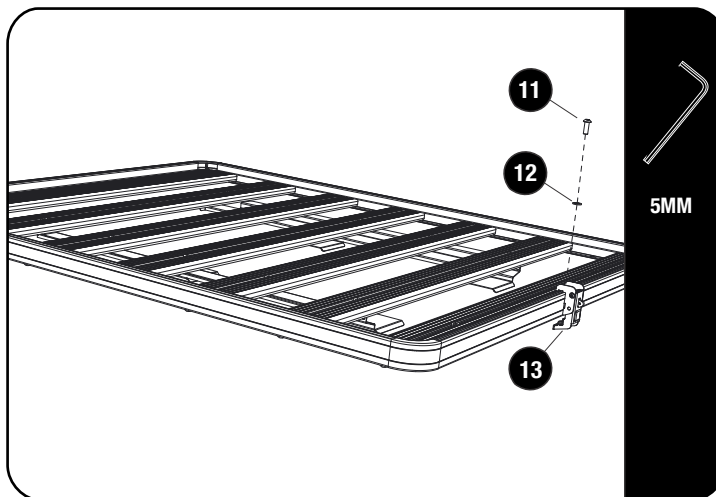

↻ Place the latch (Item 13) onto the rack, lining up the mounting hole in the latch with the Nyloc Nut in diagram 2.4. Secure the latch in position using the M8x20 button head and M8 flat washer (item 11 and 12)

2.6

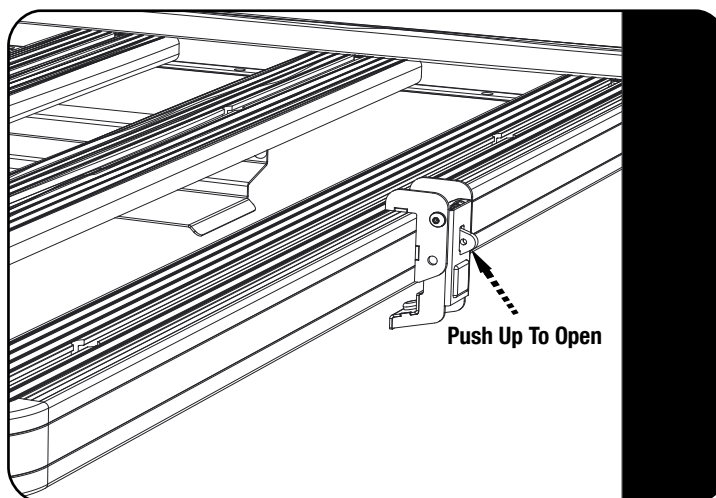

↻ Open the latch by pushing on the latch release and slide the table into position. Check that the table has no forward/backward movement when the latch is closed. If it does, loosen the Nyloc nuts (Item 6) from diagram 2.1 and adjust so that the table has no movement in the slides when the latch is closed.

A small padlock can be used through the hole in the latch release should you wish to lock the table.

3

SIDE MOUNTING WITH FOOT RAIL

3.1

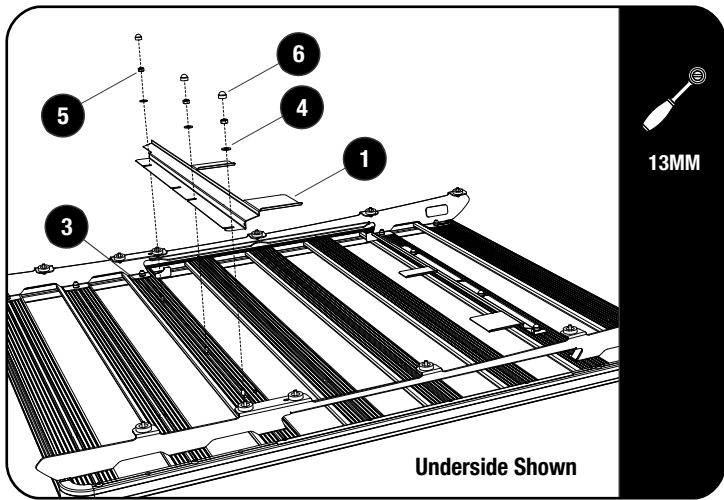

Insert three M8x16 bolts (Item 3) into the slot as shown through the machined slots. Loosely secure the table slides (Item 1) to the rack using the M8 Nyloc Nuts and M8x19 flat washers items 4 and 5 as shown.

3.2

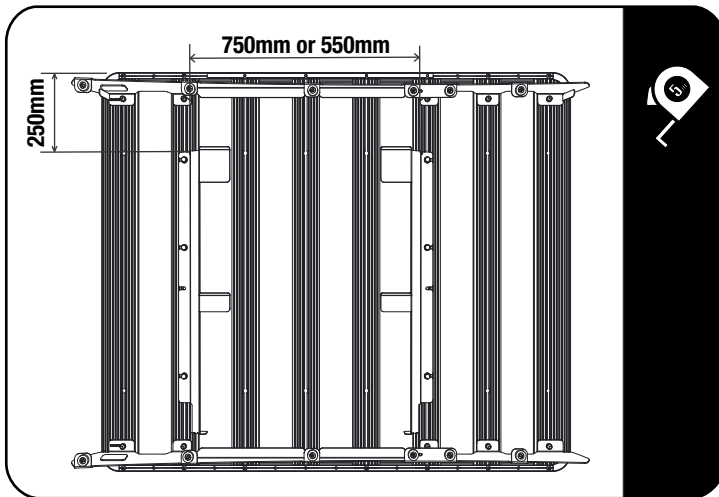

Space the table slides 250mm away from the edge of the rack as shown.

The table slides are slotted left to right to enable adjustment. Space the two table slides 750mm or 550mm apart and tighten all the Nyloc nuts. place a M8 nut cap (Item 6) over each Nyloc nut.

3.3

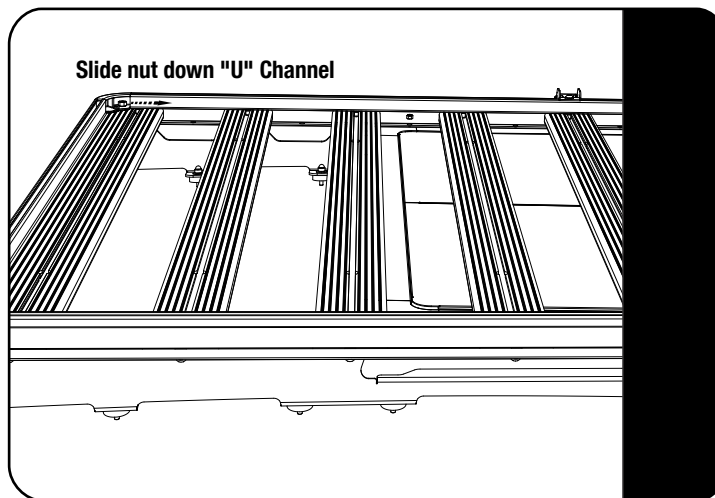

Working on the side of the rack that the table will exit, insert a M8 Nyloc nut (Item 6) dome side down into the T-Slot of the rack through the gap in the corner as shown. Slide the Nyloc nut down the T-Slot and center the nut between the two table slides.

3**SIDE MOUNTING WITH FOOT RAIL**

3.4

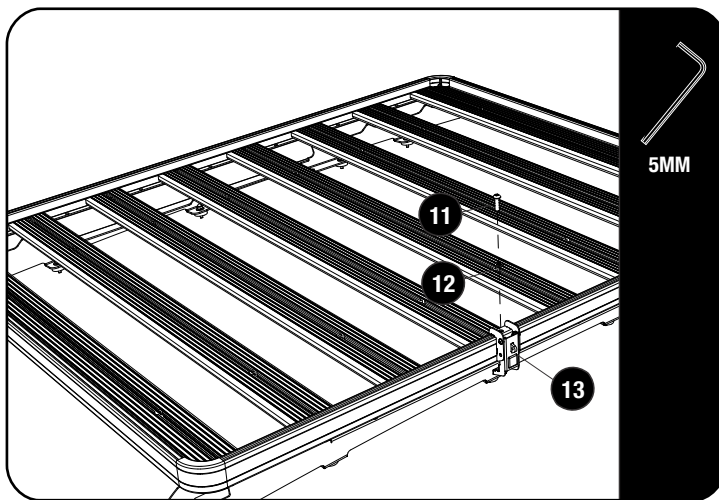

Place the latch (Item 13) into the rack, lining up the mounting hole in the latch with the Nyloc nut inserted in diagram 2.3. Secure the latch in position using the M8x20 Button head bolt and M8 flat washer (Items 11 and 12)

3.5

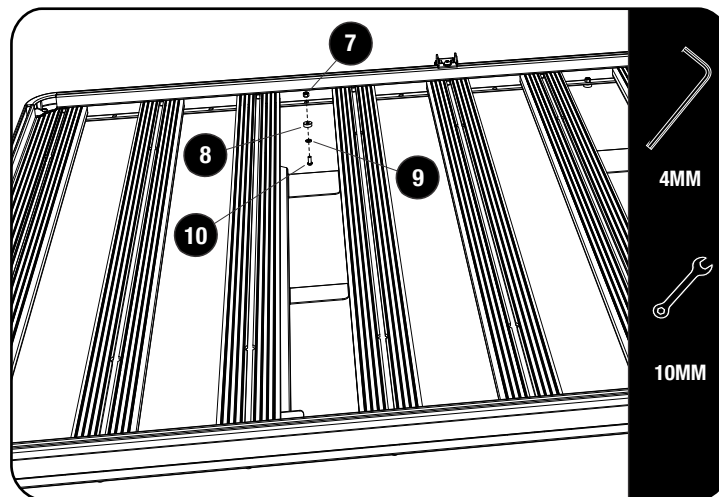

Fasten Items 7,8,9 and 10 as shown.

3.6

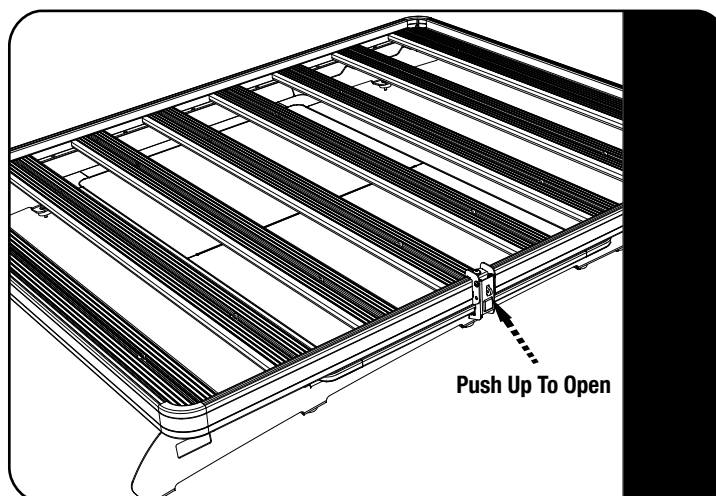

Open the latch by pushing on the latch release and slide the table into position. Check that the table has no forward/backward movement when the latch is closed. If it does, loosen the Nyloc nuts (Item 6) from diagram 3.1 and adjust so that the table has no movement in the slides when the latch is closed.

A small padlock can be used through the hole in the latch release should you wish to lock the table.

4

COMPLETION

4.1



Congratulations! You did it. Take a step back and admire your work!

4.2



Congratulations! You did it. Take a step back and admire your work!

5

INSTALL OTHER VEHICLE AND RACK ACCESSORIES

Now's the time to visit your favorite Front Runner Dealer in person or online.